

5

4

3

2

1

NOTES:

1. PARTIALLY DEFINED DRAWING.
 1. FOR ANY MISSING DIMENSIONS, REFER TO 3D MODEL #**ALK-2301-001-0001** OF SAME VERSION AS THE CURRENT DRAWING NUMBER.
 2. DIMENSIONS FROM THE 3D MODEL ARE BASIC.
 3. GENERAL TOLERANCE FOR THESE DIMENSIONS IS $\boxed{\text{0.02}}$.
2. THE PART MUST BE CLEAN AND FREE OF ANY PARTICLE, DUST, METAL CHIP AND CUTTING FLUID.
3. UNLESS OTHERWISE SPECIFIED, ALL DIMENSIONS APPLY BEFORE PAINTING OR PLATING.
4. ASSEMBLE AND PACKAGE USING WORK INSTRUCTIONS AND ENGINEERING SPECIFICATIONS (IF APPLICABLE) RELATED TO THIS PRODUCT.

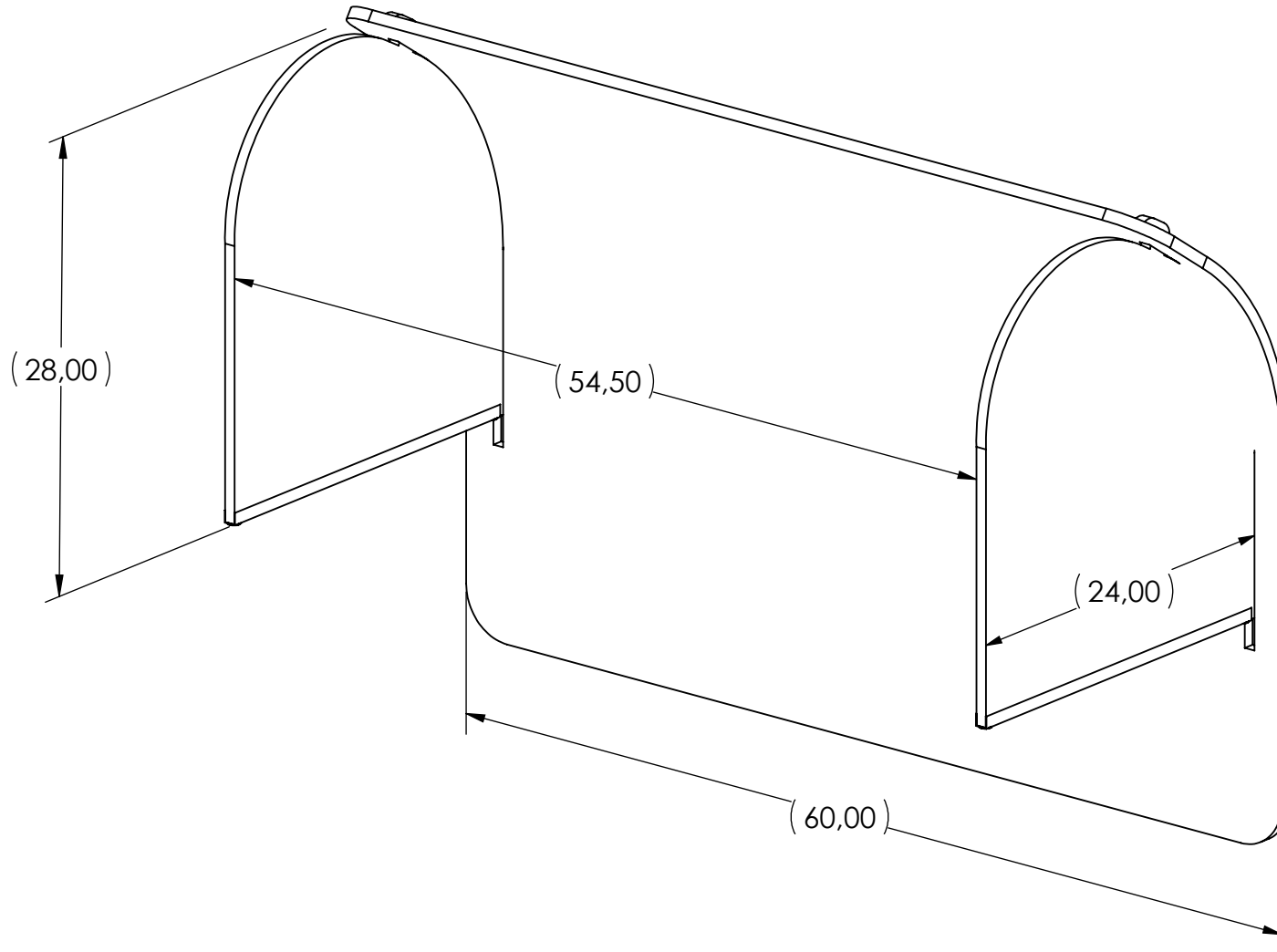

	GENERAL TOLERANCES (UNLESS OTHERWISE SPECIFIED) X.X : ± .020 X.XX : ± .010 X.XXX : ± .005 ANGLE : ± 1°	DRAWING NUMBER ALK-2301-001-0001		DRAWING TITLE HELM					
	<OPTIS-SFI> DIMENSIONS ARE IN: INCHES BREAK ALL SHARP EDGES	DESIGNED / DRAWN BY M. A.	DATE 2024-03-13	MATERIAL / SPEC DIVERS					
<small>© 9443-9965 QUÉBEC INC. 2023 THIS DRAWING IS CONFIDENTIAL AND IS THE SOLE PROPERTY OF BESPLINE (9443-9965 QUÉBEC INC.) WHO RESERVES ALL RIGHTS THEREIN. THIS DRAWING IS SUBMITTED IN CONFIDENCE FOR CONSIDERATION BY THE RECIPIENT ALONE. ANY UNAUTHORIZED USE, REPRODUCTION, DISTRIBUTION, OR DISCLOSURE OF THIS DRAWING, IN WHOLE OR IN PART, IS STRICTLY PROHIBITED UNLESS EXPRESSLY GRANTED IN WRITING.</small>		CHECKED BY	DATE	FINISH AUCUN					
		IN ACCORDANCE WITH ASME Y14.5-2009. DO NOT SCALE DRAWING.		MASS 16.710 lb	DWG REV		SCALE 1:10	SIZE A	SHEET 1/1

5

4

3

2

1